

AN8294S

Optical Disc Brush-less Spindle Motor Drive IC

■ Overview

The AN8294S is an IC for driving the Optical Disc spindle motor. It employs three-phase full-wave soft switch driving system, and its current drive do not require the electrolytic capacitor between motor windings (snubber-less). It is suitable for 4 to 12 times speed CD-ROM spindle motor drive.

■ Features

- Three-phase full-wave soft switch system used and snubber-less
- Copper block with good heat radiation built-in.
- Start/Stop terminal provided and power saved in stop mode
- The thermal shunt down detecting the junction temperature and turning off the motor current under high temperature
- FG output and rotation direction detection output terminal provided
- Current limitation function built-in, and voltage fall of detection resistance does not affect the saturation voltage
- Reverse rotation brake realized by voltage setting with EC/ECR
- Hall bias built-in
- Reverse rotation function built-in

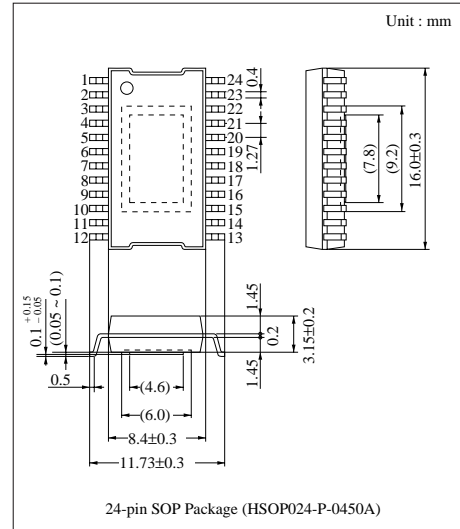

■ Pin Name

Pin No.	Symbol	Pin name	Pin No.	Symbol	Pin name
1	VH	Hall bias terminal	13	CS ₂	Current detection terminal 2
2	FG	FG signal output terminal	14	CS ₁	Current detection terminal 1
3	ECR	Torque command reference input terminal	15	A ₃	Drive output 3
4	EC	Torque command input terminal	16	A ₂	Drive output 2
5	SS	Start/Stop control terminal	17	A ₁	Drive output 1
6	RDS	Reverse rotation detection signal output terminal	18	PG	Power GND terminal
7	NC	NC	19	H ₁ ⁺	Hall element 1 positive input terminal
8	PCI	Current feedback system phase compensation terminal	20	H ₁ ⁻	Hall element 1 negative input terminal
9	V _{CC}	Power supply terminal	21	H ₂ ⁺	Hall element 2 positive input terminal
10	SG	Signal GND terminal	22	H ₂ ⁻	Hall element 2 negative input terminal
11	NC	NC	23	H ₃ ⁺	Hall element 3 positive input terminal
12	V _M	Motor power supply terminal	24	H ₃ ⁻	Hall element 3 negative input terminal

■ Block Diagram

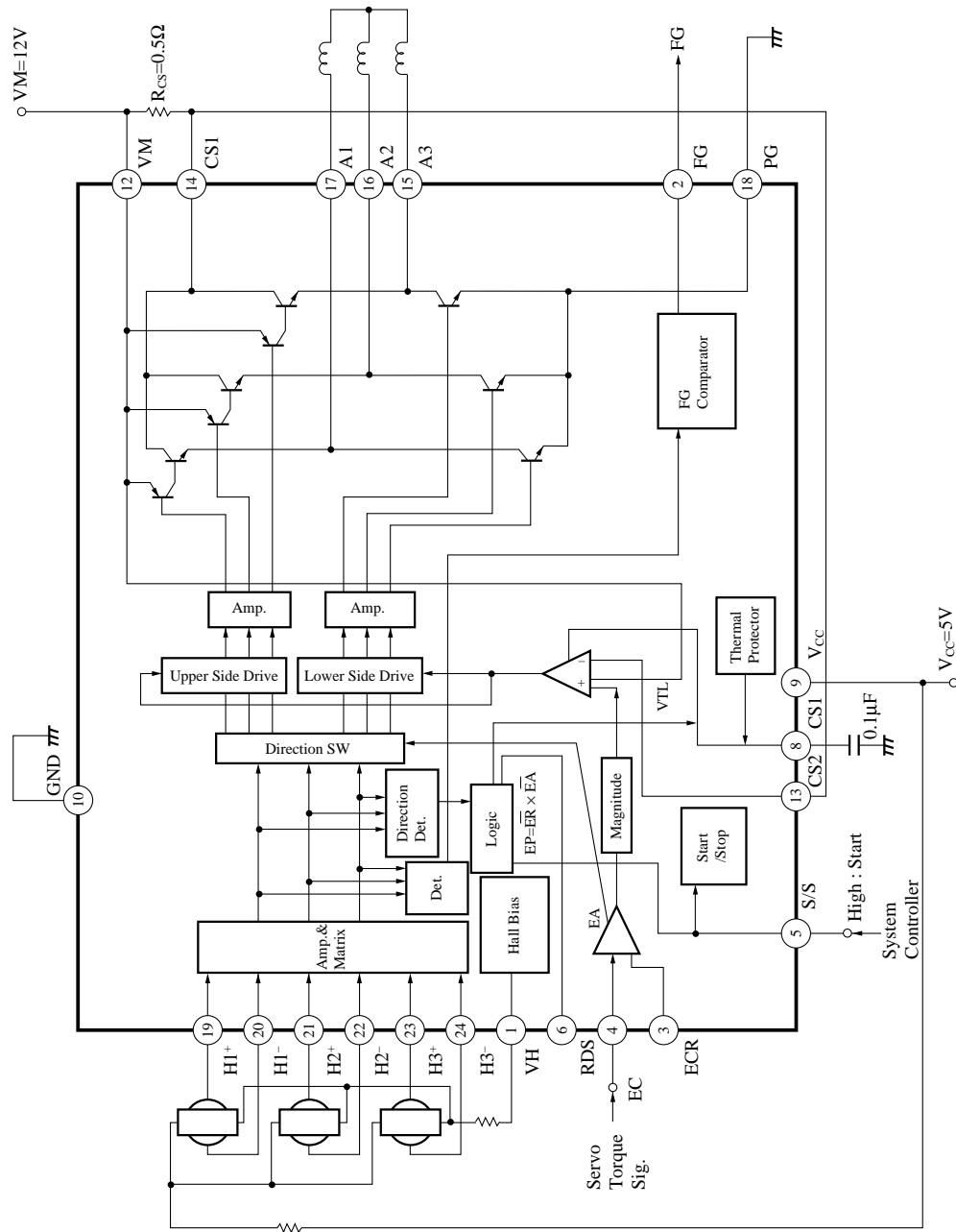

■ Absolute Maximum Rating (Ta=25°C)

Parameter	Symbol	Rating	Unit
Supply voltage	V _{CC}	7	V
	V _M	14.4	
Supply current	I _{CC}	30	mA
Output current ^{Note 1)}	I _{O (n)}	±1200	mA
Hall bias current	I _{HB}	50	mA
Control signal input voltage ^{Note 2)}	V _n	0 to V _{CC}	V
Power dissipation	P _D	909 (Ta=70°C, Single unit)	mW
Operating ambient temperature	T _{opr}	-20 to +70	°C
Storage temperature	T _{stg}	-55 to 150	°C

Note 1) Pin No.=14, 15, 16, 17, 18

Note 2) Pin No.=3, 4, 5, 19, 20, 21, 22, 23, 24

■ Recommended Operating Range (Ta=25°C)

Parameter	Symbol	Range
Operating supply voltage	V _{CC}	4.25V to 5.5V
	V _M	4.5V to 14V

■ Electrical Characteristics (Ta=25±2°C)

Parameter	Symbol	Condition	min	typ	max	Unit
Total						
Circuit current 1	I _{CC1}	V _{CC} =5V, Power Save	—	0	0.1	mA
Circuit current 2	I _{CC2}	V _{CC} =5V, I _O =0mA	—	7	14	mA
Start/Stop						
Start voltage	V _{start}	Voltage which turns on the circuit when V _{CC} =5V, L→H	3.5	—	—	V
Stop voltage	V _{stop}	Voltage which turns off the circuit when V _{CC} =5V, H→L	—	—	1.0	V
Hall Bias						
Hall bias voltage	V _{HB}	V _{CC} =5V, I _{HB} =20mA	0.9	1.2	1.6	V
Hall Amp.						
Input bias current	I _{BH}	V _{CC} =5V	—	1	5	μA
Common-mode input voltage range	V _{HBR}	V _{CC} =5V	1.5	—	4.0	V
Minimum input level	V _{INH}	V _{CC} =5V	60	—	—	mV _{P-P}
Torque Command						
Common-mode input voltage range	E _C	V _{CC} =5V	1	—	3.9	V
Offset voltage	E _{C OF}	V _{CC} =5V	-150	—	150	mV
Dead zone	E _{C DZ}	V _{CC} =5V	50	—	150	mV
Input current	E _{C IN}	V _{CC} =5V, E _C =E _{CR} =2.5V	-5	-1	—	μA
Input/Output gain	A _{CS}	V _{CC} =5V, R _{CS} =0.5Ω	0.4	0.5	0.6	A/V
Output						
Output saturation voltage H	V _{OH}	V _{CC} =5V, I _O =-300mA	—	0.9	1.4	V
Output saturation voltage L	V _{OL}	V _{CC} =5V, I _O =300mA	—	0.2	0.45	V
Torque limit current	I _{TL}	V _{CC} =5V, R _{CS} =0.5Ω	560	700	840	mA
Idle voltage	V _{idle}	V _{CC} =5V, E _C =E _{CR}	0	—	7	mV

■ Electrical Characteristics (Ta=25±2°C)







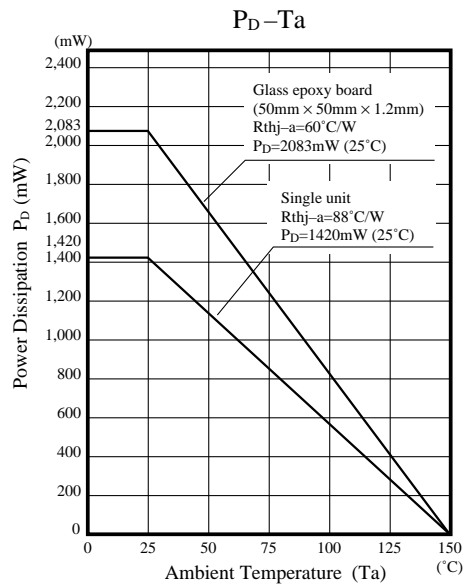



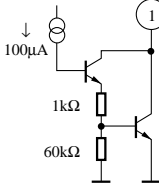

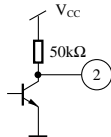
Parameter	Symbol	Condition	min	typ	max	Unit
FG						
FG output high level	FG _H	V _{CC} =5V, I _{FG} =-0.01mA	3.0	—	V _{CC}	V
FG output low level	FG _L	V _{CC} =5V, I _{FG} =0.01mA	—	—	0.5	V
Common-mode input voltage range	V _{FGR}	Input D-range of H2 ⁺ , H2 ⁻	1.5	—	3.0	V
FG hysteresis width	HFG	V _{CC} =5V	5	10	20	mV
RDS						
RDS output high level	RDS _H	V _{CC} =5V	4	—	V _{CC}	V
RDS output low level	RDS _L	V _{CC} =5V	0	—	1	V
Thermal Protection						
Thermal protection operation ^{Note)}	T _{SD ON}	V _{CC} =5V, D _{EC} =100mV	—	170	—	°C
Thermal protection hysteresis width ^{Note)}	DT _{SD}	V _{CC} =5V, D _{EC} =100mV	—	45	—	°C

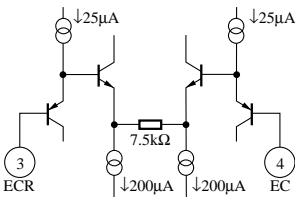
Note) These are design reference values, but not guaranteed ones.

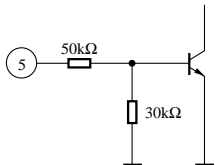
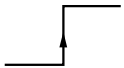
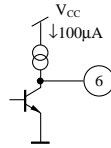
■ Package Power Dissipation



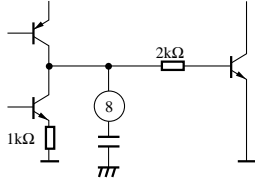





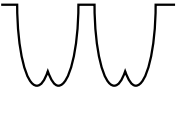
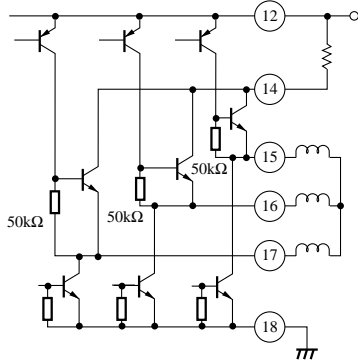
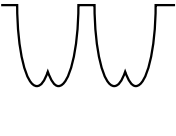
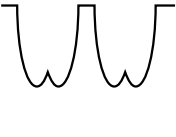



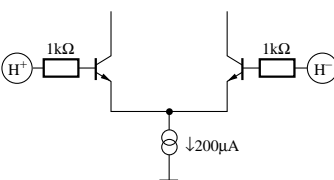

■ Pin Descriptions

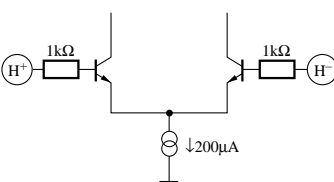
Pin No.	Pin name	Standard waveform	Description	Equivalent circuit (Note)
1	VH : Hall bias		Terminal supplying the current to the Hall element	
2	FG : FG signal output		Terminal for comparison outputting "High" or "Low" according to signals of H2 ⁺ , H2 ⁻ .	
3	ECR : Torque command reference input			
4	EC : Torque command input		Terminal inputting the command about what amount of current is flown into the motor	
5	S/S : Start/Stop control		Terminal turning on or off the IC. High : ON Low or Open : OFF	
6	RDS : Reverse rotation detection signal output		Terminal outputting the "High" or "Low" which indicates normal or reverse rotation according to the Hall element signal. H ₃ →H ₂ →H ₁ for Low H ₁ →H ₂ →H ₃ for High	
7	NC			
8	PCI : Current feedback system phase compensation		Terminal attaching the capacitor to compensate the phase for the current feedback loop	
9	V _{cc} : Supply voltage		Power supply terminal for IC	Note : The value shown above for such as bias current or resistance is not a guaranteed value, but a design reference one.
10	SG : Signal ground			

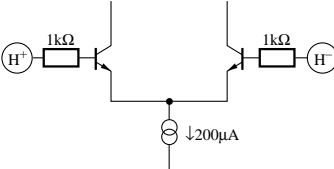
■ Pin Descriptions (cont.)

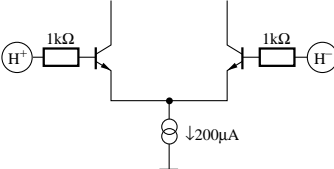
Pin No.	Pin name	Standard waveform	Description	Equivalent circuit
11	NC	————	————	
12	V _M : Motor power supply	————	Power supply terminal for supplying the power supply for motor drive	
13	CS2 : current detection 2	————	Terminal connecting the resistance to the V _M to detect the motor current amount. Normally, it is shorted with CS1.	
14	CS1 : Current detection 1	————	Common collector terminal for upper side power Tr of A1, A2 and A3	
15	A3 : Drive output 3		One of three output terminals which directly drive the motor by flowing the current in or out with two power Tr. For A1, A2 and A3, the waveform is deviated respectively by 120.	
16	A2 : Drive output 2		Same as the above	
17	A1 : Drive output 1		Same as the above	

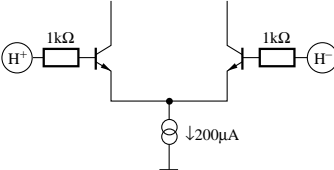
■ Pin Descriptions (cont.)

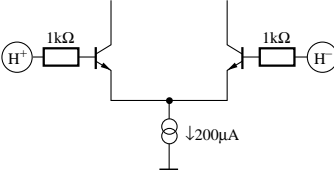
Pin No.	Pin name	Standard waveform	Description	Equivalent circuit
18	PG : Power ground		Common emitter for lower side power Tr of A1, A2 and A3	
19	H ₁ ⁺ : Hall element input		Two signals are developed from three Hall element respectively, and in total 6 signals are developed. Each signal is received by one of 6 terminals including this terminal. *Signal deviated by 180° from that for H ₁ ⁻ is applied.	
20	H ₁ ⁻ : Hall element input		Same as the above *Signal deviated by 180° from that for H ₁ ⁺ is applied.	
21	H ₂ ⁺ : Hall element input		Same as for H ₁ ⁺ *Signal deviated by 180° from that for H ₂ ⁻ is applied.	
22	H ₂ ⁻ : Hall element input		Same as the above *Signal deviated by 180° from that for H ₂ ⁺ is applied.	
23	H ₃ ⁺ : Hall element input		Same as the above *Signal deviated by 180° from that for H ₃ ⁻ is applied.	
24	H ₃ ⁻ : Hall element input		Same as the above *Signal deviated by 180° from that for H ₃ ⁺ is applied.	

■ Function Description

1) Three-phase full-wave soft switch system, snubber-less

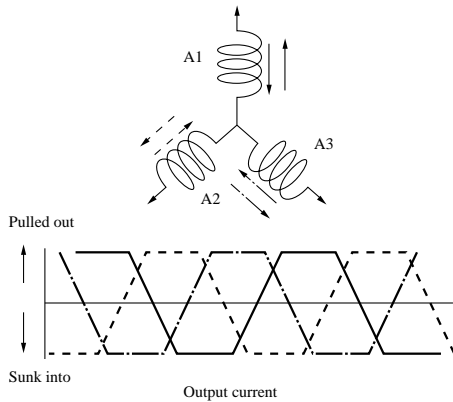

The AN8294S employs highly effective three-phase full-wave drive system, by which current is pulled out or sunk from/into each phase, A1, A2 and A3.

Current switching for each phase is done with the trapezoid-wave-shaped linear switching current. The AN8294S applies the snubber-less drive system, which does not require the external capacitor at coil ends.

2) Start/Stop terminal provided and power saved in stop mode

The circuit operation starts by "H" signal. In stop mode, the entire circuit is turned off and the bias circuit current is not flown either. Thus consumption power becomes very small.

3) TSD (Thermal Shunt Down)

The TSD detects the junction temperature, and when it exceeds the detection temperature (170 °C, typ.), it turns off the motor current. Under this condition, the consumption power is low, almost the same as when the start/stop terminal is set to the stop condition.

The TSD has hysteresis, and is automatically reset when the temperature decreases. The hysteresis width is set to 45°C (typ.).

4) Current limitation

The current limitation is achieved through detection of the voltage fall of the resistor (detection resistor) which is connected between Pins 12, 13 and 14. The detection voltage is set to 0.35V (typ.). When 0.5 Ω is connected between Pins 12, 13 and 14, the limitation current is :

$$\frac{0.35V}{0.5\Omega} = 0.70A$$

The fall of voltage between Pins 12, 13 and 14 doesn't affect the rise of saturation voltage.

In addition, Pins 13 and 14 separate the drive system and sensor system. Pin 14 CS1 is connected to the collector of upper side power Tr and functions as power supply which drive the coil. Pin 13 CS2 functions as input for drive amp. of current feedback system. Pins 13 and 14 should be shorted for use.

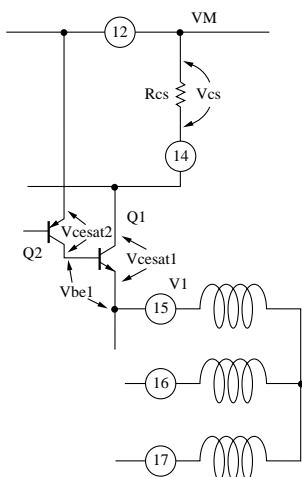

The V15 voltage of upper transistor block is given as follows :

$$V15 = VM - Vbe1 - Vcesat2 \quad \text{or} \quad V15 = VM - Vcesat1 - Vcs$$

$$\text{Therefore, } Vbe1 + Vcesat2 = Vcesat1 + Vcs$$

$$Vcesat1 - Vcesat2 = Vbe1 - Vcs$$

If the voltage drop Vcs does not exceed Vbe (the voltage between base and emitter of Q1), assuming that Q1 and Q2 have the same saturation voltage, the saturation voltage of upper side transistor block is not affected.

The above calculation can be also applied to the other phases.

The current limitation voltage is set to 0.35V. This voltage is lower than the voltage between base and emitter, and therefore the voltage fall due to detection resistance does not have a certain relationship with the saturation voltage, which affects the motor current. Thus, the AN8294S has the superior current detection system.

5) Reverse rotation brake is available by EC/ECR voltage setting.

The direction of torque applied to the motor can be changed by changing the sequence of current flowing in each output phase through voltage setting with EC/ECR. Voltage difference between EC and ECR is proportional to the motor torque (motor current) (V characteristics).

6) Hall Bias Built-in

The AN8294S incorporates the power supply for Hall element, a position sensor.

Hall bias voltage is 1.2V, typ. ($V_{CC}=5V$, Hall current is 20mA). It is almost stable, even when the supply voltage is changed.

In addition, Hall element may be connected either in series or in parallel.

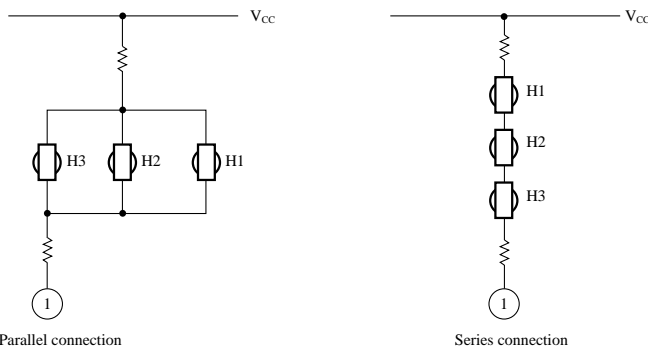

7) Reverse rotation prevention function

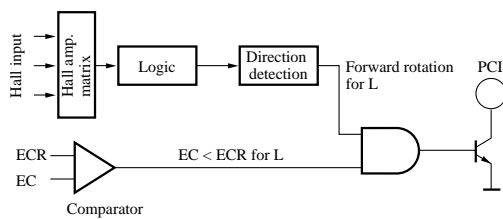

With Hall input, it detects the motor rotation direction.

When the reverse rotation of motor is detected and the reverse rotation command, $EC > ECR$, is also developed at the same time, it cuts the motor current to stop the motor.

8) Torque Command and Output Current

The voltage difference between EC terminal and ECR terminal controls the output current. (Refer to the following figure.)

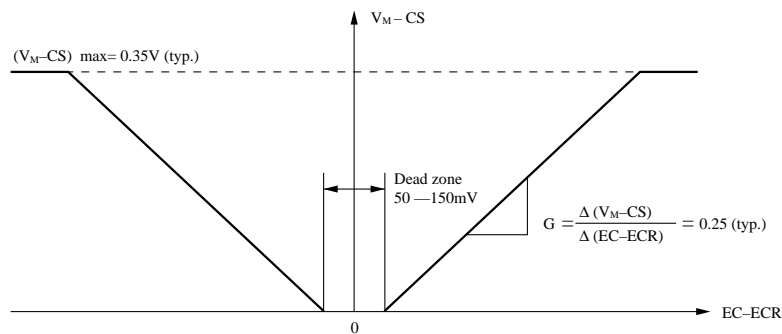

The G shown in the above figure and $(V_M - CS)_{max}$ are almost stable, independent of current detection resistance (resistance between V_M and CS terminals), R_{CS} . For example, if $R_{CS} = 0.5\Omega$,

· Transmission gain A_{CS} from EC terminal voltage to output current is :

$$A_{CS} = \frac{G}{R_{CS}} = \frac{0.25}{0.5\Omega} = 0.50 \text{ (A/V) (typ.)}$$

· Output maximum current I_{TL} is :

$$I_{TL} = \frac{0.35V}{0.5\Omega} = 0.70A \text{ (typ.)}$$

The R_{CS} should be set at the value of approximately 0.5 to 2.0 Ω .

9) Phase relationship between Hall input and output currents.

The phase relationship between Hall input and output currents when $EC < ECR$ is shown in the following figure :

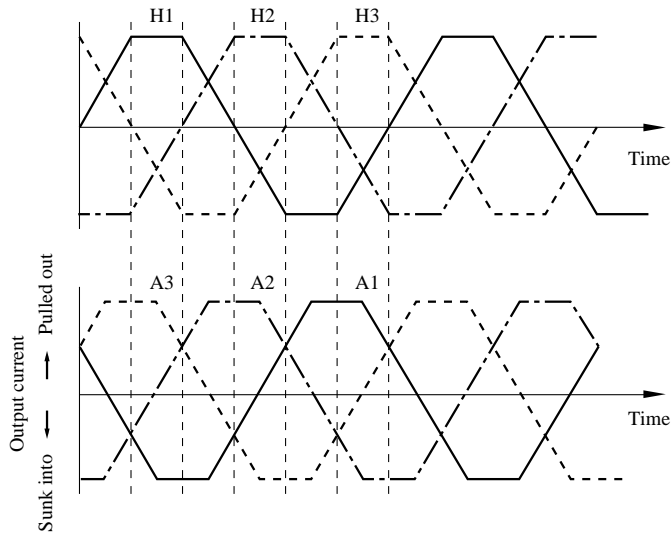

When $EC > ECR$, the pulling-out and sinking-into of the output current is just reversed from those shown in the above figure, and the motor rotation direction is reversed.

For Hall input, DC level should be set at 1.5 to 4.0V and the amplitude of each phase ($H_n^+ - H_n^-$) should be set at $60mV_{P-P}$ or more.

Phase Conditions of Hall Input and Output Current

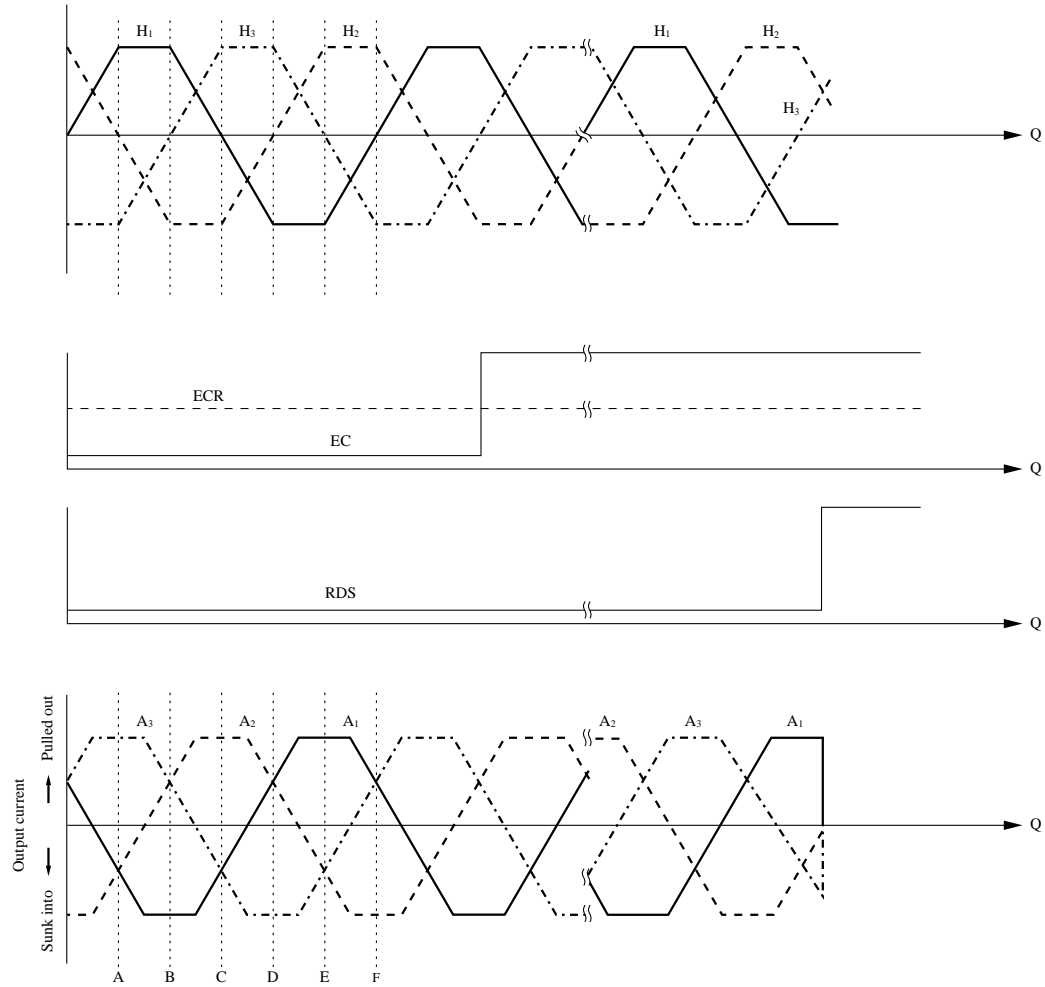

Phase of Hall Element			
	H_1^+	H_2^+	H_3^+
A	H	M	L
B	H	L	M
C	M	L	H
D	L	M	H
E	L	H	M
F	M	H	L